

AMARILLO GEAR COMPANY
QUALITY SYSTEM WORK INSTRUCTION

Subject: WORK INSTRUCTION FOR FAN DRIVE FINAL TEST & INSPECTION		Work Instruction Number QWI 10.4.1.2 Rev E
		Page 1 of 7
		Date Issued 10/11/06
		Supersedes Revision D 1/14/02
Written by: John Lucas	Approved by: Tony Stephenson	Review/Approved Date 10/11/06

SECTION	CONTENTS	PAGE NO.
2.0	Visual inspection	2
3.2	Set low oil level switch	3
3.3	Lubrication	3
4.0	Run test	4
4.6-4.8	Final inspection & special tests	4
5.0	Discrepancies	5
6.1-6.2	Diagrams for setting low oil level switch	6&7

Purpose

The purpose of this document is to provide guidelines for the final test and inspection of Amarillo Gear Company Right-Angle Fan Drives for the test stand operator or designee.

Scope

This work instruction defines the methods for the final test and inspection of complete right-angle fan drives on the test stand. Special units may require special inspections and testing at the discretion of the Engineering department. Any needed special information will be written on the drive card.

Required Equipment, Supplies and Forms

- 1.0 Horizontal variable speed motor and related controls
- 1.1 Universal test stand

NOTE: UNCONTROLLED DOCUMENT User of this document must ensure that it is the current revision.

Supersedes Revision D 1/14/02	Date Issued 10/11/06	Page 2 of 7	Work Instruction No. QWI 10.4.1.2 Rev E
----------------------------------	-------------------------	----------------	--

- 1.2 Drive shaft
- 1.3 Morlina 220 oil
- 1.4 Mobil brand Mobilgrease 28 or equivalent
- 1.5 Drive card
- 1.6 Inspection plate and Loctite Gasket Eliminator
- 1.7 1/8" combination end wrench (when required for oil level switch)
- 1.8 Special test(s) certificate forms, (when specified on drive card)
- 1.9 Special test instruments; vibration detector, digital thermometer, precision sound level meter (when special test(s) are specified on drive card)
- 1.10 5/8" pipe plug for breather replacement (when required for special shipping)
- 1.11 Wiring diagram #7484A (when drive is equipped with an electric oil pump)
- 1.12 Repaired drive card
- 1.13 Air pressure gage and air valve.

Process

- 2.0 The test stand operator shall make a visual inspection and check the following items:
 - 2.1 Verify that all regular and optional external equipment, listed on the drive card, is installed on the fan drive.
 - 2.2 Verify that all regular and optional internal equipment, listed on the drive card, that is visible through the inspection opening, is installed on the fan drive.
 - 2.3 Ensure that the model, serial number, and ratio stamped on the end of the output shaft agrees with the drive card.
 - 2.4 Verify that the serial number stamped on the inspection plate opening agrees with the drive card.
 - 2.5 When visible through the inspection opening, check the ratio of the fan drive by verifying that the ratio that is etched on the set of gears agrees with the ratio of the spiral bevel gears on the drive card.
 - 2.6 When inspecting a repaired drive, verify that all visible parts listed on repair card, internal and external, are on the drive.

Supersedes Revision D 1/14/02	Date Issued 10/11/06	Page 3 of 7	Work Instruction No. QWI 10.4.1.2 Rev E
----------------------------------	-------------------------	----------------	--

3.0 The test stand operator shall prepare for the run test by accomplishing the following items:

3.1 Move the fan drive onto the test stand and install the flexible drive shaft between the electric motor and the fan drive. Insure that the yokes of the drive shaft are in a parallel plane. Visually align the drive shaft and bolt the drive to the base.

3.2 When the fan drive is equipped with a low oil switch, set it as follows:

3.2.1 Fill the drive with the type of oil listed in step 3.5 until the oil level covers the portion of the slinger as shown in Fig. 6.1 for single reduction and Fig. 6.2 for double reduction. On model 1814, fill with oil until the oil level is 4 ½ inches below the bottom of the inspection opening. On model 2016, fill with oil until oil level is 7 ¾ below the bottom of the inspection opening.

3.2.2 Let the drive sit for fifteen (15) minutes, (thirty (30) minutes if the oil is cold) to allow the oil to completely fill the switch.

3.2.3 Remove the cover from the switch and lightly touch the indicator arm. When properly set, the microswitch will click with very little movement of the arm.

3.2.4 If the microswitch does not click, loosen the screw at the end of the indicator arm using an 1/8" combination end wrench. Move the arm until the microswitch trips, hold the arm in place, tighten the screw and repeat step 3.2.3.

3.3 When the drive is a sealed unit, prior to testing, pressure with air to 10 psi and allow to sit for at least 24 hours. See engineering if there is any pressure loss. Record results on the drive card.

Lubrication

3.4 When a drive is equipped with an electric motor powered oil pump, refer to drawing #7484A for wiring specifications.

3.5 Fill the fan drive to the proper level, (mid-point of the oil sight glass) with the oil listed below, unless special oil is specified on the drive card.

NOTE: On model A20, A22, or A27, oil level is to the middle of the oil fill elbow.

MODEL	AGMA NO	TYPE OR APPROVED EQUAL
All, Except Sealants Units	5	Morlina 220
Sealed Units	5	Mobil SHC 630

3.6 When required for special test(s), check oil temperature through inspection opening

Supersedes Revision D 1/14/02	Date Issued 10/11/06	Page 4 of 7	Work Instruction No. QWI 10.4.1.2 Rev E
----------------------------------	-------------------------	----------------	--

before mechanical run test.

3.7 Install an inspection plate gasket and inspection plate onto the inspection opening.

Mechanical Test Run

4.0 The test stand operator shall accomplish the mechanical run test by the following steps:

Safety Note: DO NOT operate the gear drive unless all protective guards are locked in position

4.1 The normal rotation for a fan drive is Figure 2. Check for special rotation of the drive, as listed on the drive card, and make certain that the drive is tested for the correct configuration as noted below:

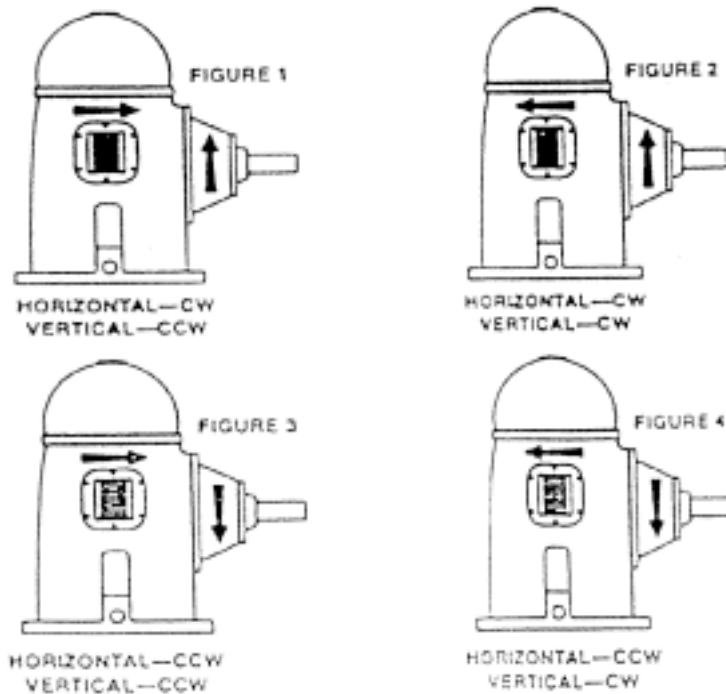

CW - Clockwise; CCW - Counter-clockwise.

4.2 With the speed adjustment control on the control panel, energize the drive motor and spin the gear drive using a controller set point of 1750 RPM.

NOTE: UNCONTROLLED DOCUMENT User of this document must ensure that it is the current revision.

Supersedes Revision D 1/14/02	Date Issued 10/11/06	Page 5 of 7	Work Instruction No. QWI 10.4.1.2 Rev E
----------------------------------	-------------------------	----------------	--

- 4.2.1 The exception to step 4.1 is when a drive is equipped with an anti-reverse sprag mechanism, as listed on the drive card. When the drive is equipped with a sprag, remove the pipe plug on top of the sprag assembly, pre-oil the sprag, spin the drive at 25 RPM, and observe the sprag through this hole to make sure it is oiling correctly, for approximately two (2) minutes. After the sprag is oiling correctly (covered with oil) replace the pipe plug and proceed with step 4.1.
- 4.3 When required for special test(s), check noise level with a sound level meter while the fan drive is running and record on test certificate form specified on drive card. If the noise level should exceed 90 dba, contact the Engineering department.
- 4.4 When required for special test(s), check vibration level with a vibration detector while the fan drive is running and record on test certificate form specified on drive card. If the vibration level should exceed .3 inches per second, contact the Engineering department.
- 4.5 Run the fan drive for one (1) minute or for as long as specified on the drive card. Remove the pipe plug from the horizontal carrier and upper intermediate bearing cover. Inspect that there is oil flow within the carrier, while the drive is running. If there is oil flow, re-affix the pipe plug and tighten.
- 4.6 Turn off the motor, detach the drive shaft and remove the drive from the test stand.
- 4.7 Verify that no oil leaks are present.
- 4.8 Check all pipe plugs and fittings for tightness.
- 4.9 When required for special test(s), check the oil temperature with a digital thermometer and record on test certificate form specified on drive card. If the temperature rise exceeds 40 degrees Fahrenheit, for a fifteen (15) minute test, contact the Engineering department.
- 4.10 When export boxing is specified on the drive card or the drive is a sealed unit, replace the breather with a 5/8" pipe plug.
- 4.11 When a drive is shipped via air freight, there will be no oil in the drive and oil will not be shipped with the drive.
- 4.12 When long-term storage is specified on the drive card, refer to form SP-18, for information about long-term storage of fan drives. Drives being shipped via air freight cannot be prepared for long-term storage.
- 4.13 When all tests and inspections are complete, stamp drive card with "TEST RUN OK BY: _____" stamp and initial. Also, initial "PARTS OK BY: _____" after parts have been checked as stated in steps 2.1 and 2.2 of this work instruction. Do not initial "OK TO SHIP BY: _____."

NOTE: UNCONTROLLED DOCUMENT User of this document must ensure that it is the current revision.

Supersedes Revision D 1/14/02	Date Issued 10/11/06	Page 6 of 7	Work Instruction No. QWI 10.4.1.2 Rev E
----------------------------------	-------------------------	----------------	--

- 4.14 When testing a repaired drive and all inspections and required tests are complete, stamp the repair card with the above mentioned stamp (step 4.10) and initial the first blank. Contact an Assembly department foreman to initial "OK TO SHIP BY: _____." and "PARTS OK BY: _____."
- 5.0 **Discrepancies:** All discrepancies noted during the final testing and inspection, not covered in this work instruction, will be handled using the following procedure.
- 5.1 Report any discrepancy to an Assembly department foreman.
- 5.2 Correct the problem with the fan drive on the test stand, if possible. Repeat the test to ensure that the problem is corrected.
- 5.3 For problems that cannot be resolved immediately, the test stand operator tags the drive with an NCM tag and the drive is moved to a bond area to await disposition.

END OF WORK INSTRUCTION

Revision E

Original or last revision issue date 1/14/02

Changes or additions were made in the following place(s):

1. Title Block
2. Required Equipment, Supplies and Forms 1.3 - Change oil from Pennzbell to Morlina 220
3. Required Equipment, Supplies and Forms 1.6 - Change oil from Pennzbell to Morlina 220

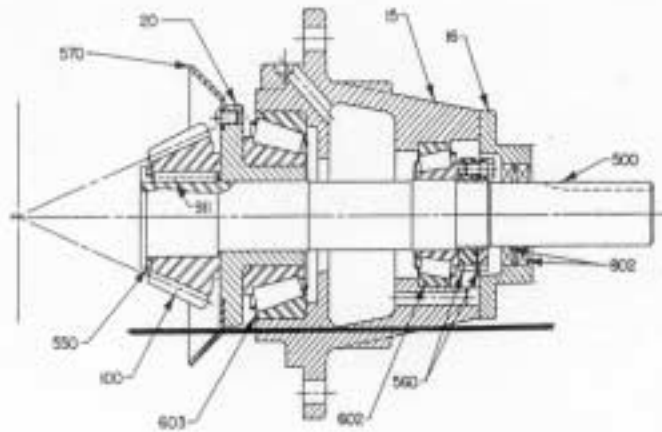

Single Reduction Fig. 6.1
Line indicates oil level on oil slinger

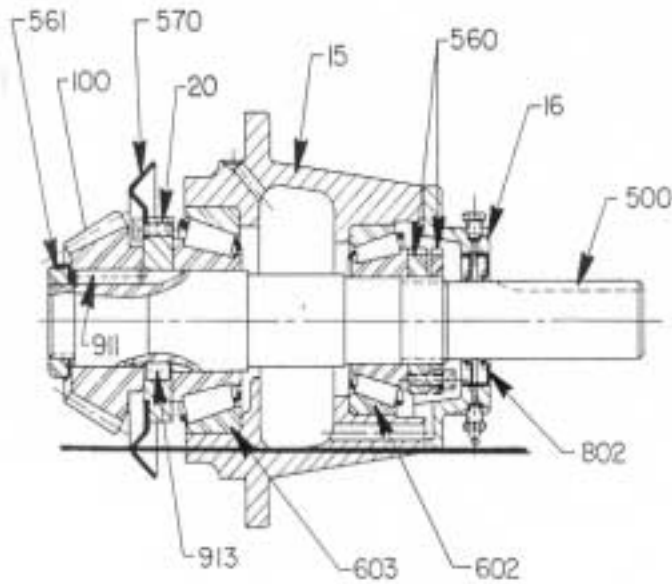

Double Reduction Fig. 6.2
Line indicates oil level on oil slinger